

**sercos**  
the automation bus

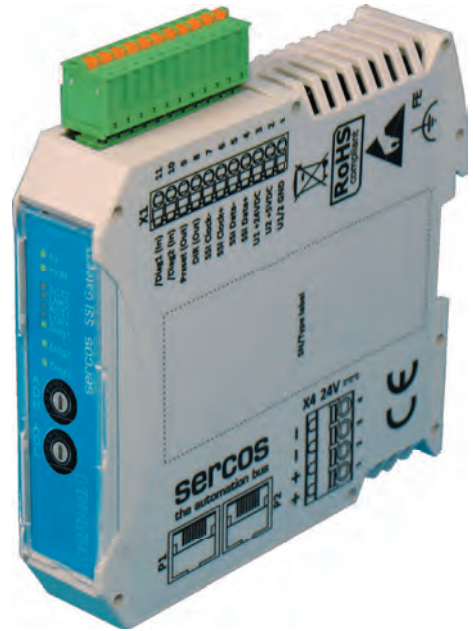

## S3SSI SSI-Gateway

- sercos 编码器配置文件 (FSP-Encoder)
- SSI 接口编码器数据信号输入
- 板载数字量输入输出通道 (I/Os)
- 探针 & 比较

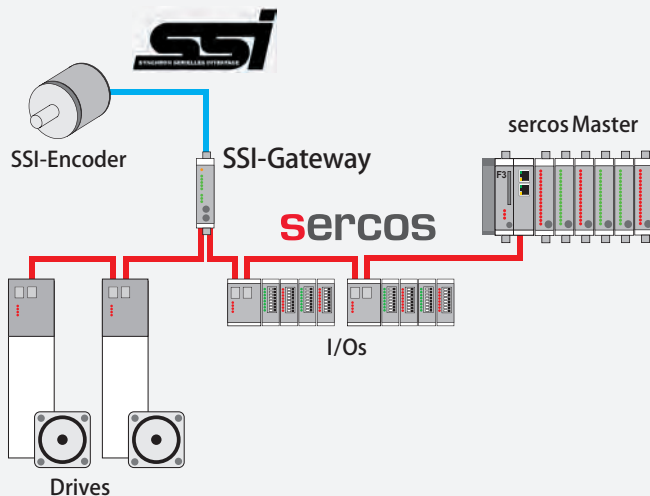

SSI-Gateway 网关模块最多支持四个SERCOS实时数据连接。这使得编码器获取的位置值不仅可以直接传输到计算机控制系统，而且还可以传输到其他从属（从站）系统 - 这对于主从轴、电子凸轮开关或电子齿轮的应用来说是一个重要特性。除了位置值之外，SSI-Gateway 网关模块还可以获取和传输速度和加速度值。

SSI-Gateway网关模块支持编码器的传输速率67.5 kHz 至2 MHz，分辨率8至31位，输出二进制或格雷码和奇数或奇偶校验。这样允许用户可选择，独立于供应商的用于特定应用的最合适的绝对值编码器。这种方式可以避免兼容性问题和对应用程序的调整。

除通过SSI接口输入数据之外，SSI-Gateway网关模块还具有可配置电压电平的数字输出：一个输出用于改变计数方向，另一个输出用于预设编码器。两个数字输入可用于获取编码器特定的诊断信息，并可用作可配置的探头输入来锁定当前位置。

- 由于SSI接口协议的广泛应用使得这SSI-Gateway网关模块，可以连接市场上所有实际应用的具有SSI接口的编码器



Technical Information		SSI-Gateway
Order Code		70069300
sercos		<ul style="list-style-type: none"> <li>sercos FSP-Encoder, Probe &amp; Compare</li> <li>4 real-time data connections</li> <li>2 rotary switches for sercos device address</li> </ul>
SSI		<b>Configuration options</b> <ul style="list-style-type: none"> <li>Transfer rates: 67,5 kHz - 2 MHz</li> <li>Encoder resolution: 8 - 31 Bits</li> <li>Binary- or Gray-Code</li> <li>none/odd/even parity</li> <li>Data Valid-Bit ON/OFF</li> <li>up to 8 data sets for different encoder</li> </ul> <b>Encoder supply</b> <ul style="list-style-type: none"> <li>24VDC/120mA or 5VDC/330mA</li> </ul>
Onboard I/Os		<ul style="list-style-type: none"> <li>2 x DigIN (24VDC)</li> <li>2 x DigOUT (24VDC/1,5mA or 5VDC/0,5mA)</li> </ul>
Dimension	H x D x W	99 mm x 114,5 mm x 22,5 mm
Power supply		24VDC (19 - 30VDC)
Weight		120 g
Housing		plastic
Mounting		DIN-rail mounting
Operating temperatur		0°C - +55°C
Protection class		IP20
Certifications		CE

## Automata Product Overview

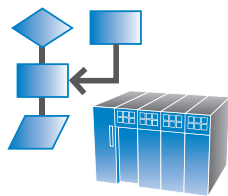

### Controls

- compact and modular controls for decentral and central system architectures
- IEC 61131-3 programmable
- Motion Control
- CAN, sercos, Profibus, Ethernet

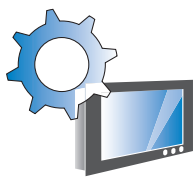

### Industrial PCs and Operator Panels

- fanless
- scalable performance
- different shapes
- different operating systems
- SoftPLC & SCADA software



### sercos products

Realtime Ethernet

- sercos hardware components and boards
- Master and slave driver software
- Control and IO systems
- Development, consulting, training



### Customized solutions

We adapt our standards to your needs. As partner of the medium-sized machine building industry we are working exactly according to your needs. Not more and not less!



Automata GmbH & Co. KG  
Gewerbering 5  
D-86510 Ried, Germany

Automata S.p.A.  
Via G. Carducci, 705, I-21042  
Caronno Pertusella (VA), Italy

[www.cannon-automata.com](http://www.cannon-automata.com)



上海丰林科技有限公司  
Fenglin Technologies Ltd.  
Tel. : + 86(21)6247 4478  
Fax : + 86(21)5093 3892  
eMail: [sales@fltech.com.cn](mailto:sales@fltech.com.cn)

上海浦东大道1139弄1号1305室  
Room 1305, No.1, Lane 1139  
Pu Dong Avenue, Shanghai  
200031 China

技术支持 Technical support :  
eMail: [roy.shen@fltech.com.cn](mailto:roy.shen@fltech.com.cn)

[www.fltech.com.cn](http://www.fltech.com.cn)