

- Contactless, robust sensor system
- Infinite resolution, no hysteresis
- Calibrated output signals:
0(4) to 20 mA, ± 10 VDC, or 0 to 10 VDC
- Accuracy 0.5% or 0.25%
- Cylindrical housing with M30 x 1.5 external mounting thread
- Protection class IP 66

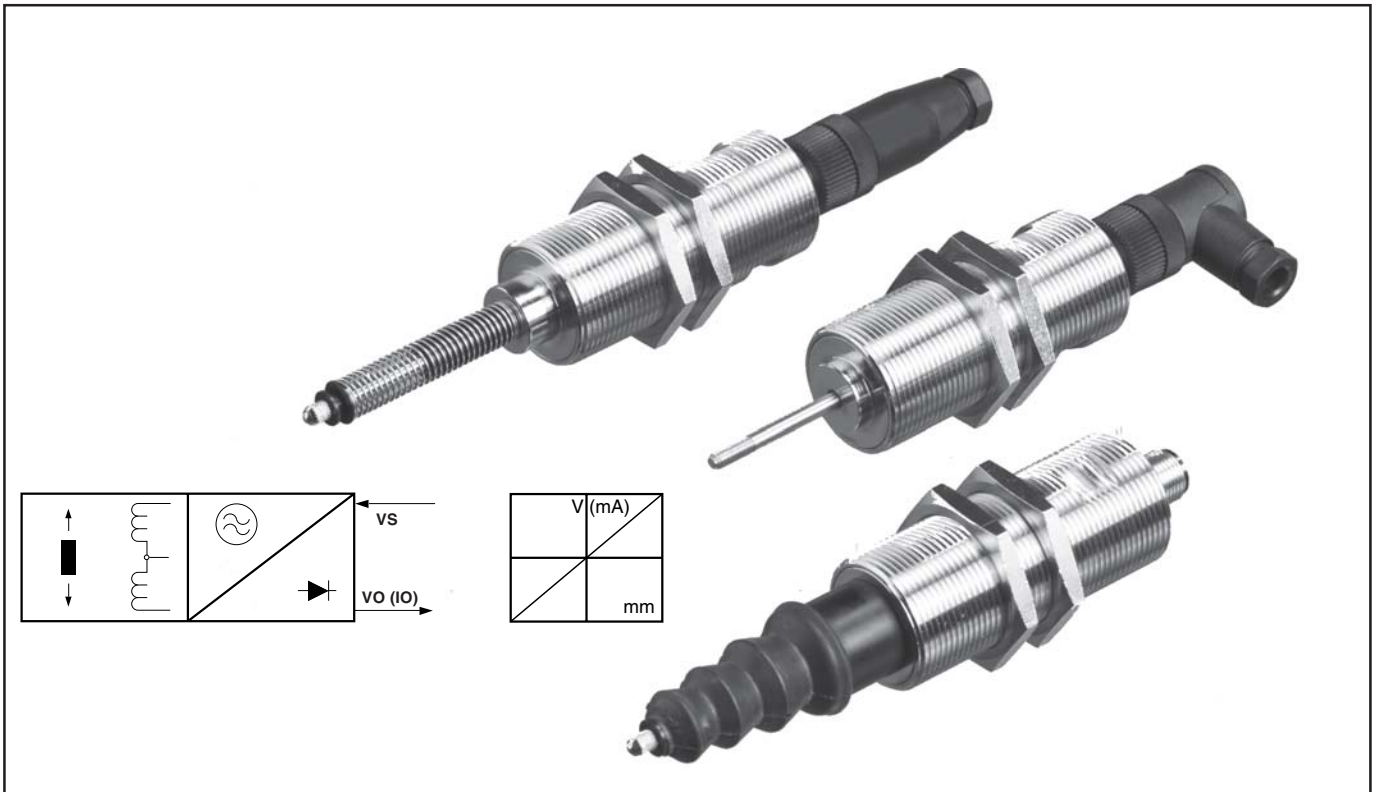

Construction and operating principle

The displacement transducer operates according to the principle of the differential choke, i.e. an inductive half bridge. It consists of two coils which are encapsulated in a round nickel plated brass housing. A mu-metal plunger core causes opposing changes of inductance when it is displaced through the centre of the coils. These changes are converted by the integral electronic circuit into a signal proportional to the displacement. The circuit contains an oscillator, demodulator, amplifier and the output stage. It is short-circuit proof and protected against reverse polarity.

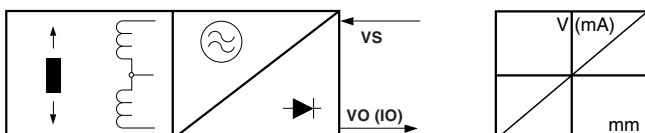

The housing consists of nickel plated brass, the plunger shaft is in stainless steel. The external thread allows for easy mechanical zero point adjustment. The transducers are completely sealed to ensure protection against vibration, shock, humidity, oil and corrosive matter. They can be supplied either with lead or connector exit. The index can be adjusted by screwing the device into the measuring position.

Standard measuring strokes : 5, 10 and 15 mm

Independently of the measuring stroke the mechanical travel of the plunger is 18 mm. Shorter measuring ranges can be calibrated upon request.

Standard versions and calibration

Type	Output-signal*	V _s *	Midpoint at
IWM 301	0 ... 20 mA	21,5 ... 32 V	10 mA
IWM 303	4 ... 20 mA	21,5 ... 32 V	12 mA
IWM 305	± 10 VDC	$\pm 13 \dots \pm 16$ V	0 V
IWM 30A	0 ... 10 VDC	21,5 ... 32 V	5 V

* Increasing signal when the plunger is moved in the direction towards the electrical connections.

** Other supply voltages on request

Technical Data

- Supply voltage V_s : 21.5 to 32 VDC or (prot'd against reverse polarity) ± 13 to ± 16 VDC
- Accuracy : 0.5% or 0.25%
- Temperature drift : $\leq \pm 0.05$ % / °C
- Stability : $\leq 0.1\%$ in 24 hours
- Measurement frequency : ≤ 100 Hz
- Operating temperature range : -10°C to $+80^\circ\text{C}$
- Storage temperature range : -30°C to $+80^\circ\text{C}$
- Resistance to shock : 250g SRS at 20 to 2000 Hz
- Resistance to vibration : 20g rms (50g peak) at 20 to 2000 Hz
- Protection class : IP 66
IP 67 with STK 65

Current output (IWM 301 and 303)

- Current signal : 0 to 20 mA or 4 to 20 mA
- Supply current I_s : 60 mA max.
- Load resistance R_L :
□ at $V_s = 21.5$ to 32 VDC 0 to 500 Ω
- Ripple : < 0.005 mA_{p,p}
- Dependence on R_L : $< 0.001\%$ for $\Delta R_L = 100$ Ω
- Dependence on V_s : $< 0.05\%$ for $\Delta V_s = 1$ V
- Maximum output current : 25 mA

Voltage output (IWM 305 and 30A)

- Voltage signal : ± 10 VDC or 0 to 10 VDC*
- Supply current I_s : 50 mA max.
- Permissible load R_L : 2 k Ω (short-circuit proof)
- Ripple : < 5 mV_{p,p}
- Dependence on V_s : $< 0.05\%$ for $\Delta V_s = 1$ V
* residual voltage 0,1 VDC max.

Note: Unless otherwise stated, all values are valid at $+20^\circ\text{C}$ ambient temperature and 30 VDC or ± 15 VDC supply voltage, starting 10 minutes after switch-on.

Order code format IWM 300

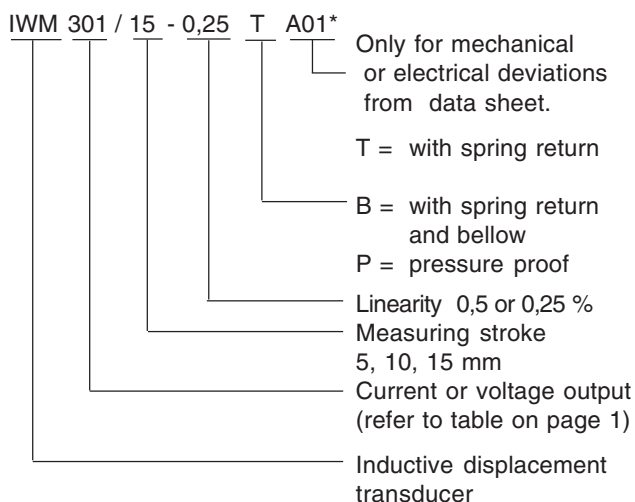

* The applicable A-No. is specified according to the definition of the deviation when ordering. No A-No. is given for standard versions as defined in this the data sheet.

Electrical connections in the plug

(view towards the connection part of the device)

Connections

IWM 301, IWM 303, IWM 30A	
1	= $+V_s$
2	= n.c. (not connected)
3	= $+I_o / V_o$
4	= V_s (0V)

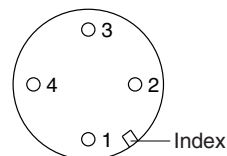

Connections

IWM 305	
1	= $+V_s$
2	= 0V
3	= $+V_o$
4	= $-V_s$

Counter plug for IWM 300

(to be ordered separately)

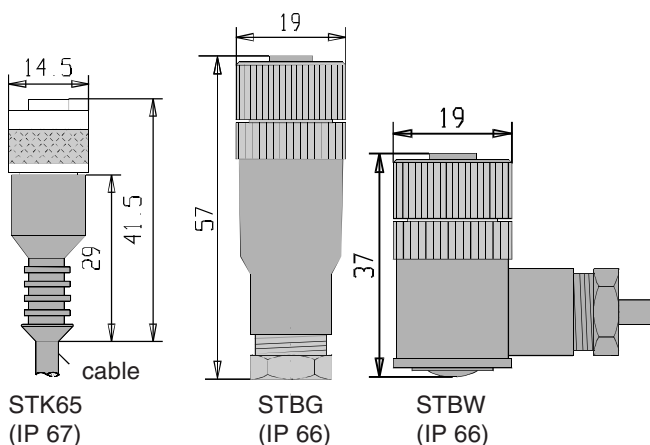

The counter plug STK65 will be delivered with sealed cable :

- Length 6.50 m
- Copper wire 0.34 mm²
- Common shielding
- PVC coating
- cable diameter 5 mm

Dimensions in mm

Standard

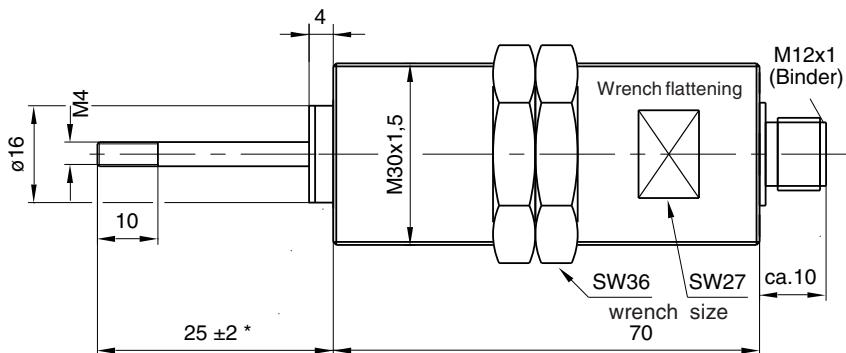

Gauge (T)

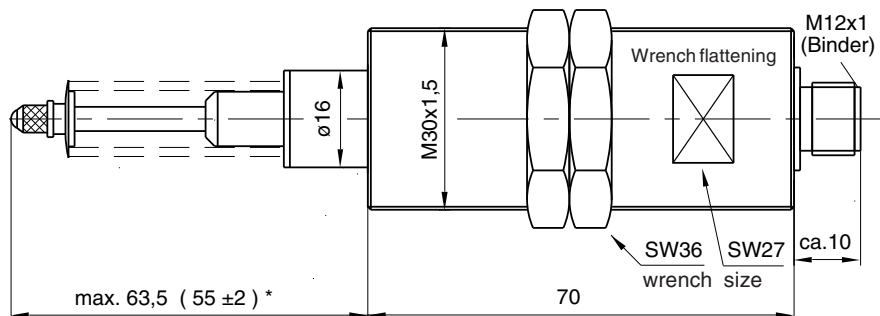

For gauge type IWM 300 ... T und IWM 300 ... B

Measuring stroke	Pre-travel	Over-travel
5 mm	6 mm	7 mm
10 mm	3,5 mm	4,5 mm
15 mm	1 mm	2 mm

Gauge with bellow (B)

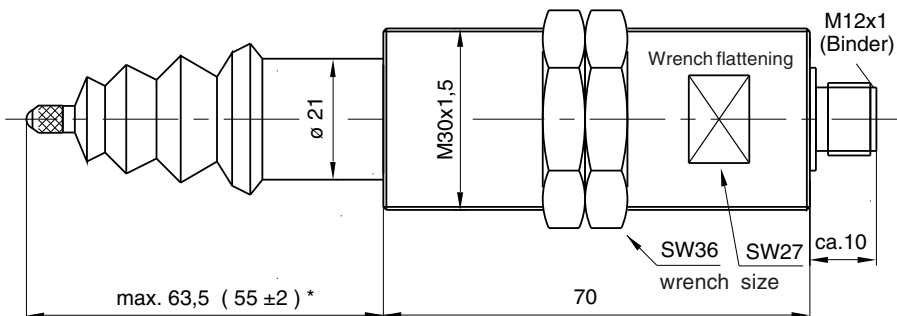

Pressure proof (P)

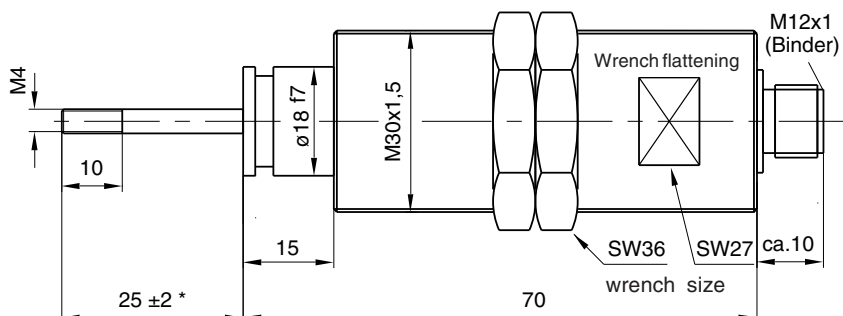

(*Plunger at mid-point)