

Absolute multiturn encoder TRK with EtherCAT® - interface

Document no.: TRK 12825 FE

Date: 13.09.2013



- Contactless, wear-free sensor system according to the Hall principle
- High vibration and shock resistance thanks to the robust mechanical design
- Resolution: 4096 steps / 360° ↻ - 12 bit (13 bit optional)
- Measuring range: 4096 revolutions (12-bit)
- Dual-chamber system for separating the rotor and electronics
- Protection type: IP 66 or IP69K
- Operating temperature range: - 40°C to + 85°C

Design and function

Recording of the angular position and revolutions by means of Hall sensors - absolute multiturn transmission for up to 4096 revolutions - data output plus parameterisation and diagnosis via EtherCAT.

Robust housing (housing thickness 5 mm) manufactured from seawater-resistant aluminium (AlMgSi1) or stainless steel - stainless steel shaft - ball bearing with shaft seal - sensors circuit consisting of ASIC with Hall elements - electrical connection via M12 connector or cable outlet.

In the model series TRK absolute encoders, the EtherCAT interface is integrated according to IEC 61158-2 to 6 and encoder profile CiA DSP406.

As a "full slave", the TRK supports all EtherCAT addressing modes such as logical addressing, position addressing and node addressing.

Use of the CANopen over EtherCAT message and the CANopen encoder profile enable parameter and diagnostic data handling as familiar from CANopen. These are contained in an object directory under the same indices as in the case of CANopen. The process data are transmitted in PDOs whose composition is defined via PDO mapping.

The project planning and commissioning of a TWK absolute encoder with EtherCAT interface are described in detail in the [CRK 11780](#) user manual.

EtherCAT® features

- Complex slave with CANopen over EtherCAT (CoE)
- "Full slave" - all addressing modes except segment addressing
- All EtherCAT write/read services
- Field-bus Memory Management Unit (FMMU)
- Sync-manager
- Distributed Clocks (on request)

EtherCAT® is a registered brand and patented technology licensed by Beckhoff Automation GmbH, Germany.

Absolute multiturn absolute encoder model TRK

Technical Data

Input data *

- 4 byte position data
- 2 byte speed data (on request)

Output data *

- 2 byte control

Electrical data

- Sensor system: ASIC with Hall-elements
- Operating voltage: + 9 VDC to + 36 VDC
- Power consumption: < 3 W, switch-on current < 500 mA
- Resolution: 4096 steps / 360° (12 bit)
(13 bit optional)
- Measuring range: 4096 revolution
- Total number of steps: 24 bit (optional 25 bit)
- Accuracy: ± 0.2 % (with reference to one revolution)
- Output code: Binary
- Code path: CW / CCW
- Internal updating time: ≤ 2 ms

Mechanical data

- Operating speed: 4.000 rpm max.
- Angular acceleration: 10⁵ rad/s² max.
- Moment of inertia (rotor): 20 gcm²
- Operating torque: ≤ 2 Ncm
- Starting torque: ≤ 3 Ncm
- Perm. shaft load: 250 N axial
250 N radial
- Bearing service life **: > 10⁹ revolutions Approx
- Weight: ca. 0.450 kg (stainless steel version: ca. 0.7 kg)

Environmental data

- Operating temperature range: - 40 °C to + 85 °C
- Storage temperature range: - 40 °C to + 100 °C (without packing)
- Resistance:
 - To shock: 500 m/s²; 11 ms
DIN EN 60068-2-27
 - To vibration: 500 m/s²; 10 ... 2000 Hz
DIN EN 60068-2-6
- EMC: DIN EN 61000-6-2 (interference immunity)
DIN EN 61000-6-4 (interference emission)
- Protection type: IP 66 or IP69K
(DIN EN 60529)

Electrical connection

- EtherCAT: M12 connector D-coded 4-pin for bus in / bus out, socket
- Supply: M12 connector A-coded 4-pin, pins

EtherCAT mating connector

- Connection type: M12 connector D-coded 4-pin
- Housing: Die-cast zinc, nickel-plated
- Contacts: Pins, gold
- Wire connection: Cage clamp
- Connection cross-section: max. 0.75 mm²
- Cable diameter: 6 - 8 mm

* From the point of view of the control system.

** These values apply at maximum shaft load. Higher values are achievable at lower loads.

Absolute multiturn absolute encoder model TRK

Technical Data

- Protection type: IP 67

Supply mating connector

- Connection type: M12 connector A-coded 4-pin
- Housing: Die-cast zinc, nickel-plated
- Contacts: Socket, gold
- Wire connection: Screw connection
- Connection cross-section: max. 0.75 mm²
- Cable diameter: 4-6 mm
- Protection type: IP 67

Pre-assembled Industrial Ethernet data cable

- Connection type: M12 connector D-coded 4-pin
- Contacts: Pins, gold
- Cable type: PUR, halogen-free, Profinet type C
- Cable cross-section: 4 x 0.38 mm² (AWG 22)
- Cable diameter: 6.2 mm
- Protection type: IP 67

Programmable parameters

Parameter	Value range	Parameter description
Code path	CW / CCW	CW (clockwise): ascending values on rotation clockwise CCW (counter clockwise): descending values on rotation clockwise (viewed looking at the shaft).
Resolution [steps/360°]	1 ... 4096 (8192)	Steps per revolution (360°)
Total number of steps [steps]	1 ... 16777,216 (33,554,432)	Overall measuring range
Reference value	0 ... total number of steps -1	For adaptation to the application, the position value can be set to any value within the measuring range. Once programmed, a reference value can be set via bit 0 in the control word (output data).

(The values in brackets apply to the TRKxx-xx8192R4096C1MKxx)

Data format

Input data (position value)

Byte 0								Byte 1								Byte 2								Byte 3							
7	6	5	4	3	2	1	0	15	14	13	12	11	10	9	8	23	22	21	20	19	18	17	16	31	30	29	28	27	26	25	24
position_value																															

Representation in Intel format (Little Endian).

Output data (control word)

Byte 0								Byte 1							
7	6	5	4	3	2	1	0	15	14	13	12	11	10	9	8
control_value															

Absolute multiturn absolute encoder model TRK

Electrical connection

Principle circuit

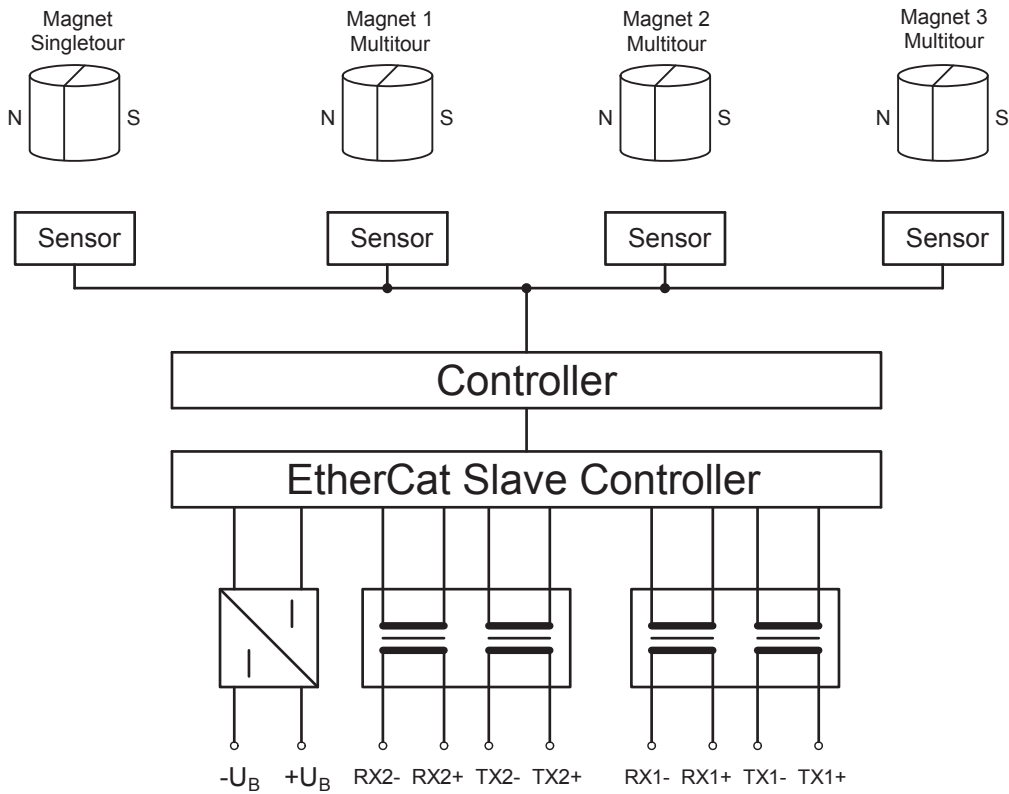

EtherCAT M12 connector connection assignment

(Port1 and Port 2)

PIN	1	2	3	4
Signal	TX+	RX+	TX-	RX-
Colour*	yellow	white	orange	blue

* Industrial Ethernet cable colours according to ISO / IEC 8802-3.

Supply M12 connector connection assignment

PIN	1	2	3	4
Signal	+ UB (+ 24 VDC)	—	- UB (0 VDC)	—

Absolute multiturn absolute encoder model TRK

Electrical connection

Diagnostic-LED`s:

UB	Link/ Activity1 (L/A1)	Link/ Activity2 (L/A2)	Status (NS)	Description
green	green	green	green/red	
on				Operating voltage available
	on			Network connection established
	Flashing			Network active
		on		Network connection established
		Flashing		Network active
			off	Initialisation
			green/ 1 x flashing	Safe operational
			green/ normal flashing	Pre-operational
			green on	Operational
			red flashing	Impermissible parameter or preset value
			red on	No response from the master

Absolute multiturn absolute encoder model TRK

Order number

Encoder

TRK	58	-	KP	A	4096	R	4096	C1	M	K	01
<p>Electrical and / or mechanical variants*</p> <p>01 Standard</p> <p>02 Protection type IP69K</p> <p>03 Aligned device connectors</p> <p>K EtherCAT-interface</p> <p>Electrical connection:</p> <p>M M12 connector</p> <p>Kx Cable, x=length in m</p> <p>S Special connector</p> <p>Profile:</p> <p>C1 Standard EtherCAT</p> <p>Measuring range:</p> <p>4096 revolutions</p> <p>Output code:</p> <p>R Binary</p> <p>Resolution:</p> <p>4096 steps / 360° ↵</p> <p>8192 steps / 360° ↵</p> <p>Housing material:</p> <p>A Aluminium</p> <p>S Stainless steel</p> <p>Flanschart:</p> <p>58 K Clamped flange, shaft 10 mm with flat</p> <p>KF Clamped flange, shaft 10 mm with woodruff key</p> <p>KP Clamped flange, shaft 10 mm with parallel key</p> <p>KZ Clamped flange, shaft for play-compensating toothed gear ZRS</p> <p>S Synchronizer flange, shaft 6 mm</p> <p>SR Synchronizer flange, clamping shaft 12 mm</p> <p>ST Synchronizer flange, shaft 6 mm with flat</p> <p>64 NZ Cam switch flange, shaft for ZRS</p> <p>65 S Synchronizer flange, shaft 12 mm</p> <p>SP Synchronizer flange, shaft 12 mm with parallel key</p> <p>66 K Clamped flange, shaft 10 mm with flat</p> <p>90 MP Mounting flange, shaft 12 mm with parallel key</p> <p>105 M Mounting flange, shaft 12 mm</p> <p>MP Mounting flange, shaft 12 mm with parallel key</p> <p>Design form</p> <p>Model:</p> <p>TRK T series multiturn with EtherCAT interface</p>											

* The basic versions according to the data sheet bear the number 01. Deviations are identified with a variant number and are documented in the factory.

Absolute multiturn absolute encoder model TRK

Order number

Accessories (to be ordered separately)

- Documentation on CD
 - TWK-CD-01** CD-ROM with documentation, device description file, bitmap and example programme
- Straight mating connector
 - STK4GP81** for EtherCAT in/out
 - STK4GS60** for the supply voltage
- Angled mating connector (can only be used with aligned device connectors (option))
 - STK4WP82** for EtherCAT in/out
 - STK4WS61** for the supply voltage
- Connecting cable
 - KABEL-xxx-114** Industrial Ethernet data cable with M12 connectors, D-coded, moulded on at both ends. Standard lengths: 1, 2, 3 and 5 m (xxx = length in metres)
 - KABEL-xxx-118** Industrial Ethernet data cable with M12 connector on RJ 45, IP 20 (xxx = length in metres)
- Couplings
 - BKK** Folding bellows coupling, large, see data sheet [BKK11840](#)
 - BKM** Folding bellows coupling, small, see data sheet [BKM11995](#)
 - KK14S** Clamp coupling, see data sheet [KK12301](#)
- Toothed gear
 - ZRS** Play-compensating toothed gear [ZRS11877](#)
- Torque plate
 - ZMS** see data sheet [ZMS12939](#)
- Further installation accessories and securing clamps are available according to data sheet [MZ10111](#) .

Documentation, EDS file, etc.

The following documents plus the EDS file, a bitmap and example programmes can be found in the Internet under www.twk.de in the documentation area, model TRK

- Data sheet No. TRK12825
- Manual No. [CRK 11780](#)

Optionally, a CD-ROM can be supplied. (Please specify article No. TWK-CD-01 on ordering.)

Absolute multiturn absolute encoder model TRK

Dimensions in mm

Standard design form

Design form 58 with clamped flange, Order number: TRK58-KA 4096 R 4096 C1 M K01

Shaft \varnothing 10 mm

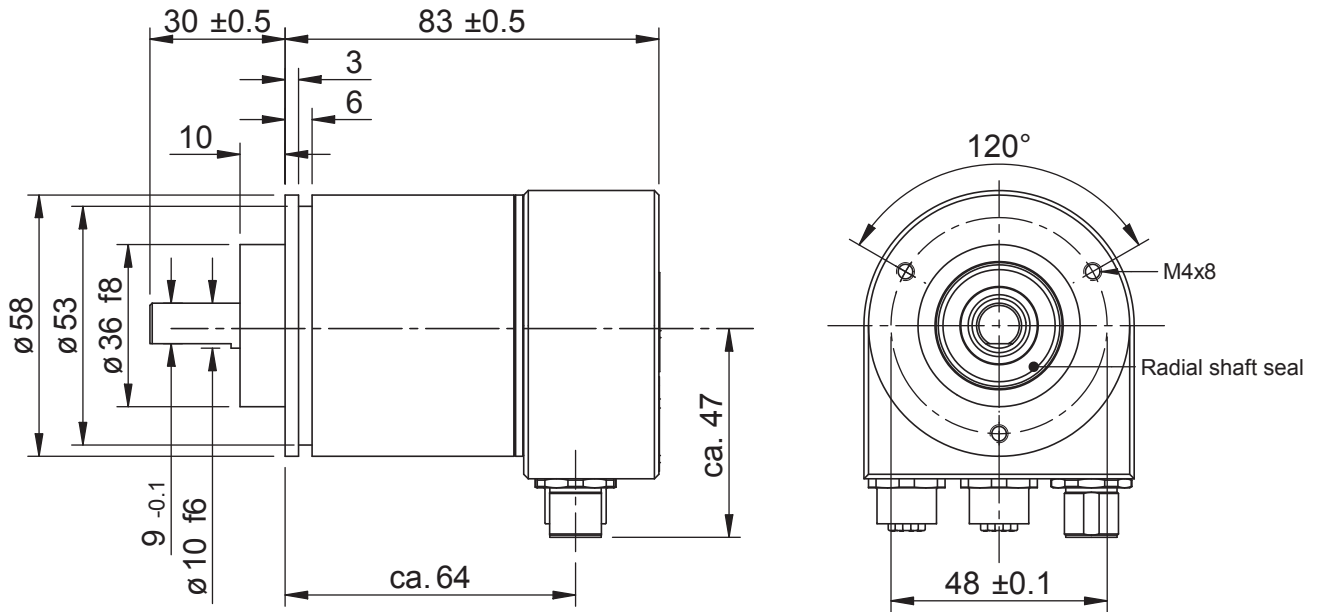

■ Optional: Shaft "P" with groove and fitted spring

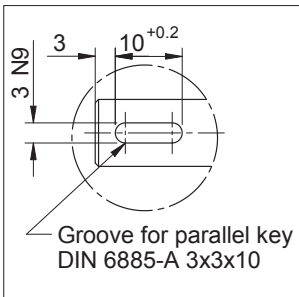

View backside

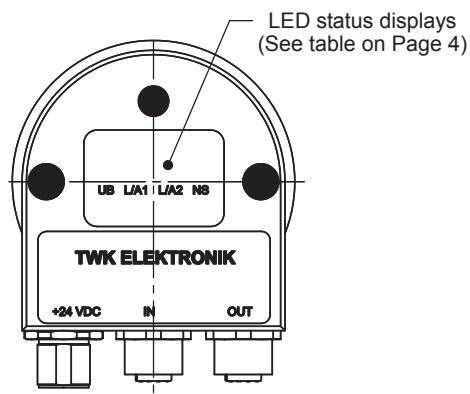

Absolute multiturn absolute encoder model TRK

Dimensions in mm

Further design forms

Design form 58 with **synchroniser flange**, Order number: TRK58-SA 4096 R 4096 C1 M K01

Shaft \varnothing 6 mm

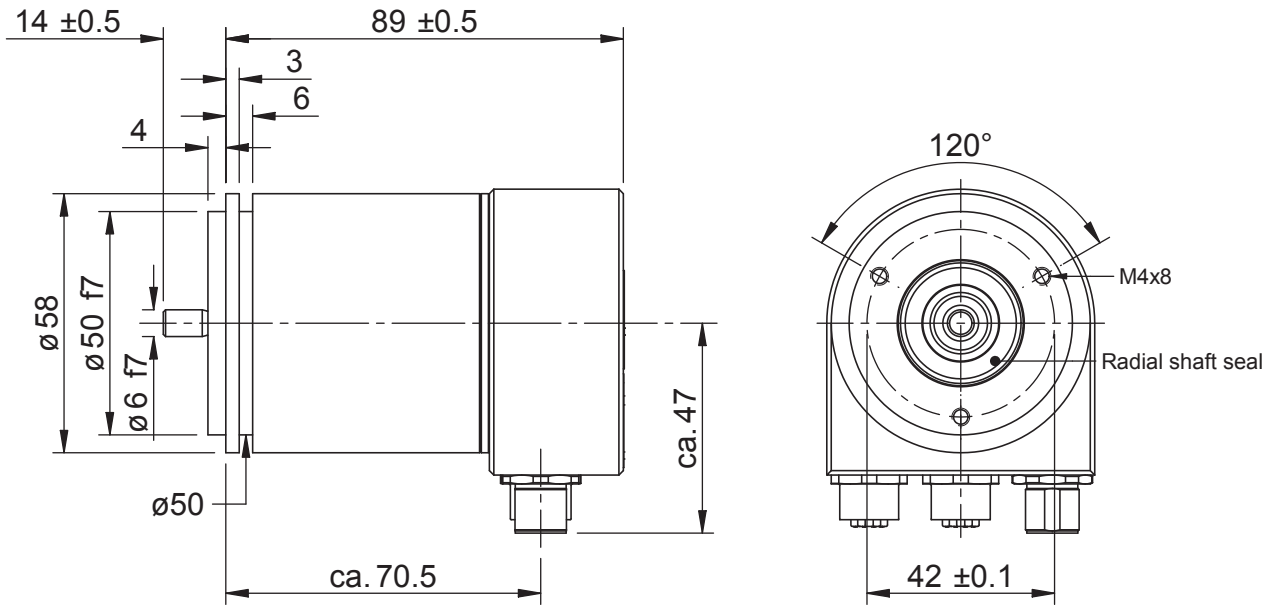

Design form 65 with **synchroniser flange**, Order number: TRK65-SA 4096 R 4096 C1 M K01

Shaft \varnothing 12 mm

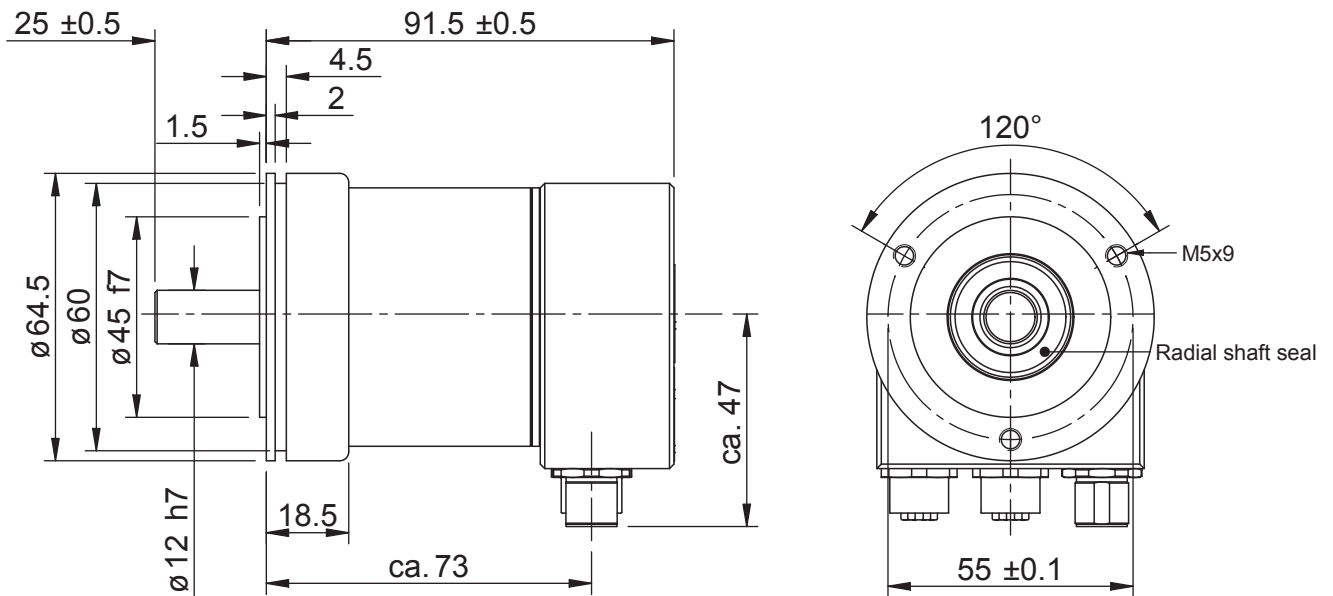

■ Optional: Shaft "P" with groove and fitted spring

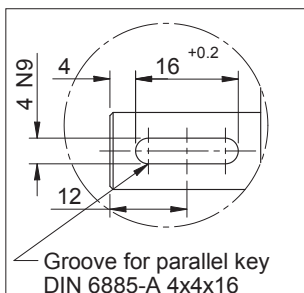

Absolute multiturn absolute encoder model TRK

Dimensions in mm

Design form 58 with **synchroniser flange and clamping shaft**,
 order number: **TRK58-SRA 4096 R 4096 C1 M K01**

Clamping shaft \varnothing 12 mm

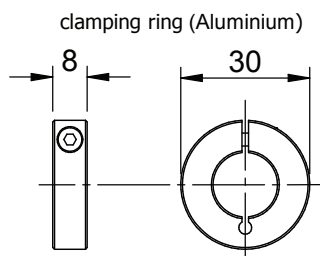
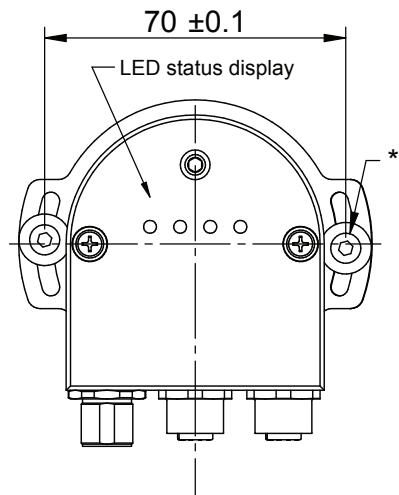
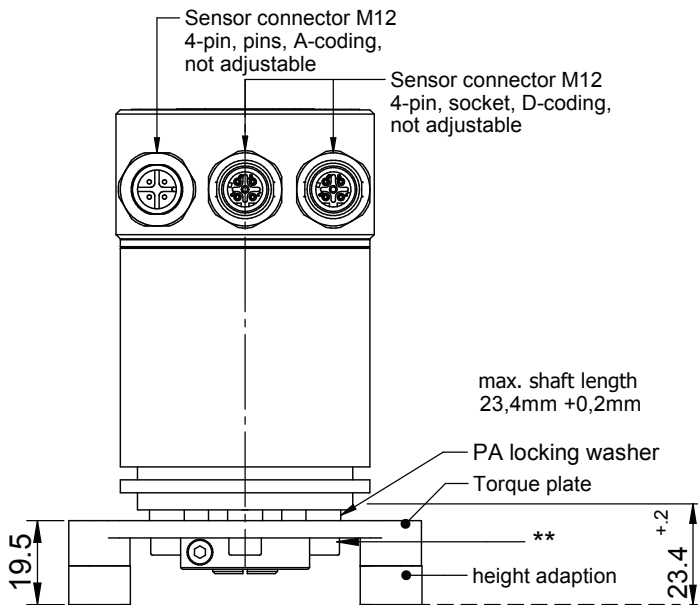
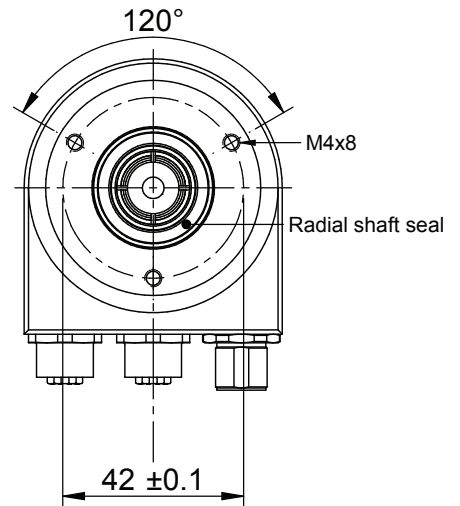
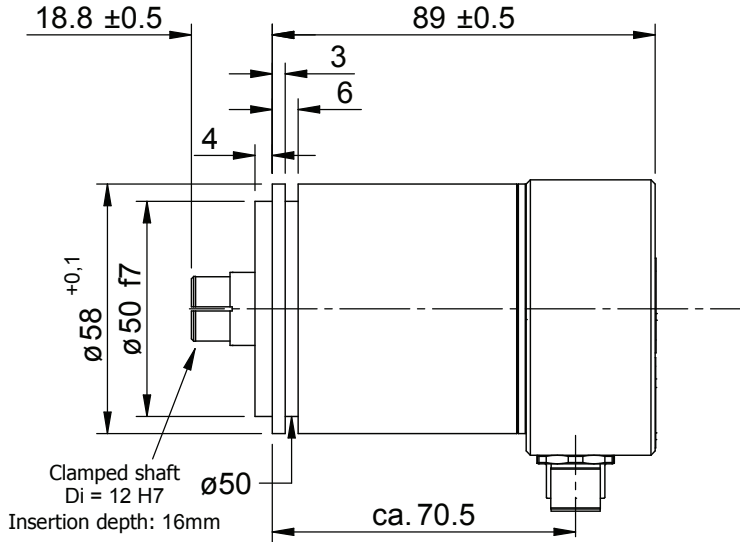

* 2x screw DIN 912 M4x30 (VA) with 2x locking washer (VA) and 2x flat washer DIN 9021-4,3.

** 3x screw DIN 912 M4x10 (VA) with 3x locking washer (VA).