

Absolute encoder TRT with PROFINET interface

Document no.: TRT 12886 IE

Date: 03.09.2015



- Singleturn and multiturn versions
- Contactless, wear-free sensor system according to the Hall principle
- High vibration and shock resistance thanks to the robust mechanical design
- Position and speed signal
- Resolution: up to 8192 steps / 360° ↯ (13-bit)
- Measuring range: up to 4096 revolutions
- Protection type: up to IP69K
- Operating temperature range: - 40°C to + 85°C
- PI certified PROFINET interface
- Option: Special slewing ring software for non-reversing operation

Design and function

Recording of the angular position and revolutions by means of Hall sensors - multiturn version with absolute multiturn transmission for up to 4096 revolutions - data output plus parameterisation and diagnosis via PROFINET.

Robust housing manufactured from seawater-resistant aluminium or stainless steel - stainless steel shaft - ball bearing with radial shaft seal - sensor circuit consisting of ASIC with Hall elements - electrical connection via M12 connector or cable outlet.

The Profinet interface according to IEC 61158 / 61784 or PNO specifications order No. 2.712 and 2.722, version 2.2, is integrated into the model series TRT absolute encoders. Real time classes 1 - 3 are supported, i.e. Real Time (RT) and Isochronous Real Time (IRT) plus the requirements of conformance class C.

Setting the address, baud rate or terminating resistances is not necessary. A name, which is stored in the absolute encoder's non-volatile memory, is assigned via the PROFINET controller to address the device.

The integrated 2-fold switch enables the TWK PROFINET absolute encoders to be used in star, tree and line network topologies.

An exhaustive description of integration into a PROFINET network can be found in the manual [TRT12887](#).

In the version with code type "S" the TRT offers a slew ring functionality. This converts the sensor shaft position value into the position of a slewing ring or a rotary table.

The slew ring encoder permits the adjustment of the number of teeth of the slew ring and of the encoder gear-wheel via the encoder parameters. In this way all gear ratios are possible and the encoder can be adapted to any slew ring by the user. The output values are the position of the slew ring in degrees (resolution adjustable) and his velocity in degree / time basis (time basis adjustable).

PROFINET properties

- Real Time (RT) and Isochronous Real Time (IRT)
- Device exchange without interchangeable medium or programming device
- Prioritised start-up (Fast Start Up)
- Media redundancy possible
- Firmware update via Profinet
- Programming via Profinet

Absolute encoder model TRT

Technical data

Input data *

- 4-byte position data
- 2-byte speed data

Output data *

- 4-byte reference value

Electrical data

- Sensor system: ASIC with Hall elements
- Operating voltage: + 9 VDC to + 36 VDC (polarity reversal protection)
- Power consumption: < 3 W, switch-on current < 500 mA
- Resolution: 4096 steps / 360°< - (12-bit) or 8192 steps / 360 °< - (13-bit)
- Measuring range: 4096 revolutions (only multiturn version)
- Total number of steps: Singleturn: 12 or 13 bit, multiturn: 24 or 25 bit
- Absolute accuracy of the position value: ± 0.2% (with reference to one revolution)
- Internal updating time of the position value: 1 ms
- Output code: Binary
- Code path: CW / CCW
- Speed signal: 16-bit, with prefix, unit: steps / gate time (gate time adjustable in the 10 ... 1000 ms range, default: 10 ms)
- Internal updating time of the speed signal: 1 ms

PROFINET data

- MAC address: 00:0E:CF:XX:XX:XX
The relevant, current MAC address is located on the model plate.
- Transfer technology: 100 Base-TX
- Transfer rate: 10 / 100 MBit/s
- Line length: Max. 100 m (between two subscribers)
- Minimum transmission cycle: 250 µs

Mechanical data

- Operating speed: 1.000 rpm max. (optional 10.000 rpm max.)
- Angular acceleration: 10⁵ rad/s² max.
- Moment of inertia (rotor): 20 gcm²
- Operating torque: ≤ 8 Ncm (at 500 rpm)
- Starting torque: ≤ 4 Ncm
- Perm. shaft load: 250 N axial, 250 N radial (Flange form HP: 500 N axial and radial)
- Bearing service life **: > 10⁹ revolutions
- Weight: ca. 0.450 kg

Environmental data

- Operating temperature range: - 40°C to + 85°C
- Storage temperature range: - 20°C to + 60 °C (due to packaging)
- Resistance
 - To shock: 500 m/s²; 6 ms (DIN EN 60068-2-27)
 - To vibration: 250 m/s²; 5 ... 2000 Hz (DIN EN 60068-2-6)
- EMC standards: EN 61000-6-4 (interference emission)
EN 61000 6-2 (interference immunity)
- Protection type: IP 67, with cable output IP 68, IP 69K optional (DIN EN 60529)
- Salt mist test: Test Kb according to IEC 60068-2-52

* From the point of view of the control system.

** These values apply at maximum shaft load. Higher values are achievable at lower loads.

Absolute encoder model TRT

Technical data

Electrical connection

- PROFINET: M12 connector D-coded 4-pin for bus in / bus out, socket or cable outlet
- Supply: M12 connector A-coded 4-pin, pins or cable outlet

PROFINET mating connector

- Connection type: M12 connector D-coded 4-pin
- Housing: Die-cast zinc, nickel-plated
- Contacts: Pins, gold
- Wire connection: Cage clamp
- Connection cross-section: Max. 0.75 mm²
- Cable diameter: 6 - 8 mm
- Protection type: IP 67

Supply mating connector

- Connection type: M12 connector A-coded 4-pin
- Housing: Die-cast zinc, nickel-plated
- Contacts: Socket, gold
- Wire connection: Screw connection
- Connection cross-section: Max. 0.75 mm²
- Cable diameter: 4-6 mm
- Protection type: IP 67

Pre-assembled Industrial Ethernet data cable

- Connection type: M12 connector D-coded 4-pin
- Contacts: Pins, gold
- Cable type: PUR, halogen-free, Profinet type C
- Cable cross-section: 4 x 0.38 mm² (AWG 22)
- Cable diameter: 6.2 mm
- Protection type: IP 67

Cable outlet PROFINET

- Cable type: PROFINET Type-C, 4 x 0,36 mm² (AWG22)
- Cable jacket: PUR, color: green
- Temperatur range: - 40 °C to + 70 °C
- Outer diameter: 6,5 mm ± 0,2 mm
- Min. bend radius: 5 x d fixed installation, 10 x d freely movable

Cable outlet power supply

- Cable type: 2 x 0,75 mm², shielded
- Cable jacket: PUR, color: gray
- Temperatur range: - 40 °C to + 80 °C fixed installation, - 5 °C to + 70 °C freely movable
- Outer diameter: 6 mm
- Min. bend radius: 6 x d fixed installation, 15 x d freely movable

Absolute encoder model TRT

Technical data

Programmable parameters

Standard encoder

Parameter	Value range	Parameter description
Scaling	Off / On	
Code path	CW / CCW	CW (clockwise): ascending values on rotation clockwise CCW (counter clockwise): descending values on rotation clockwise (viewed looking at the shaft)
Resolution [steps/360°]	1 ... 4096 (8192)	Steps per revolution (360°)
Total number of steps [steps]	1 ... 16,777,216 (33,554,432) or 4096 (8192) for singleturn encoder	Overall measuring range
Gate time	10 ... 1000 ms	Time basis for speed registration
Reference value	0 ... total number of steps -1	For adaptation to the application, the position value can be set to any value within the measuring range. Once programmed, a reference value can be set via bit 0 in the control word (output data).

(The values in brackets apply to the TRTxx-xxx8192R4096C4MTxx)

Slew ring encoder

Parameter	Value range	Parameter description
Code path	CW / CCW	CW (clockwise): ascending values on rotation clockwise CCW (counter clockwise): descending values on rotation clockwise (viewed looking at the shaft)
Number of teeth slewing ring	1 ... 65535	Number of teeth of the machine*s slewing ring
Number of teeth encoder pinion	1 ... 65535	Number of teeth of the encoder pinion which gears in the slew ring
Resolution position [steps]	1 ... 8192 x i	Desired resolution of the slew ring position, e.g. 3600 for a resolution of 0,1°. The maximum possible value depends on the gear ration i.
Resolution for speed calculation [steps]	1 ... 8192 x i	The resolution of the slew ring used for the velocity calculation. This parameter can be adjusted independent of the parameter "Resolution position", e.g. 36000 for a velocity resolution of 0,01° / gate time. The maximum possible value depends on the gear ration i.
Gate time [ms]	10 ... 1000	Time basis of the velocity measurement
Reference value [steps]	1 ... resolution position	To adapt to the users application the encoder can be set to any value within the measuring range. The preset function is processed via the output values and can be executed in the user programm of the PLC.

t = Gear ratio *Number of teeth slewing ring to Number of teeth encoder pinion*

Absolute encoder model TRT

Electrical connector

Block diagram

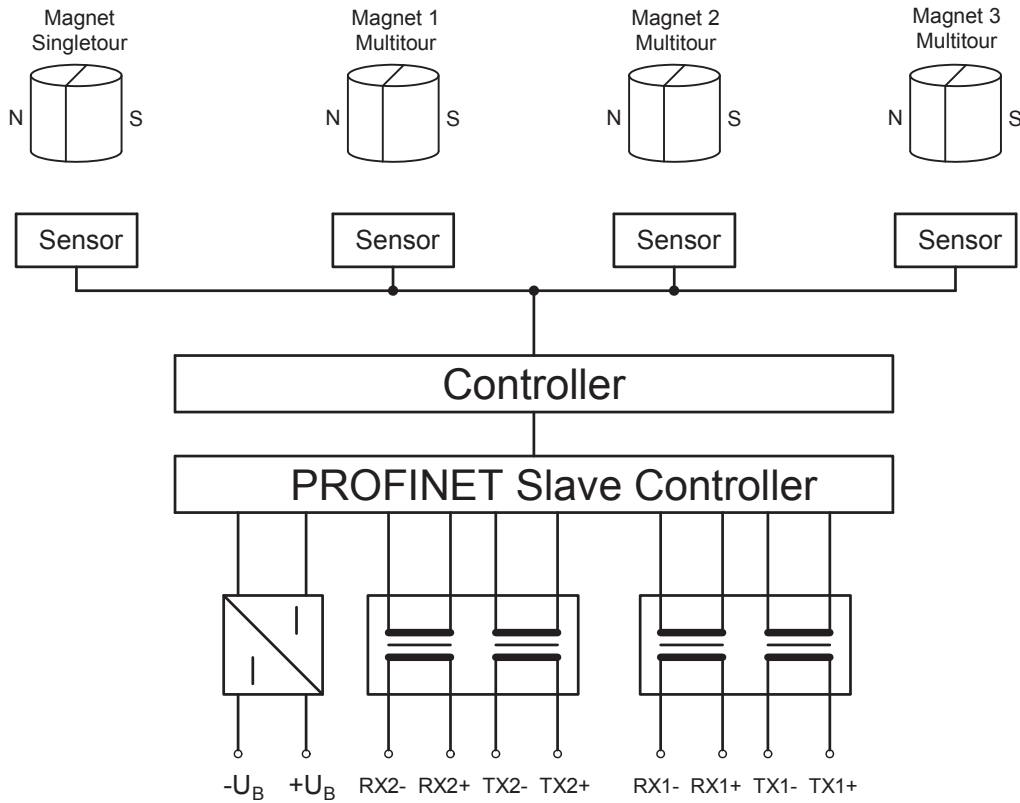

PROFINET M12 connector connection assignment
(Port1and Port 2)

PIN	1	2	3	4
Signal	TX+	RX+	TX-	RX-
Colour*	yellow	white	orange	blue

Supply M12 connector connection assignment

PIN	1	2	3	4
Signal	+ UB (+ 24 VDC)	—	- UB (0 VDC)	—

* Industrial Ethernet cable colours according to ISO / IEC 8802-3.

Absolute encoder model TRT

Diagnosis-LED`s

UB (VS)	Link 1 (L1)	Link 2 (L2)	Status (NS)	Description
green	green	green	green/red	
on				Operating voltage available
	on			Network connection established
		on		Network connection established
			green	Data exchange, device in operation and OK
			gren flashing	Network connection o.k. but no connection to a PROFINET controler
			red, slow flashing	Firmware download mode
			red flashing	Impermissible parameter or preset value
			Fast red flashing	Device error
			red	Connection to the PROFINET controller disrupted

Absolute encoder model TRT

Order number

TRT 58 - K A 8192 R 4096 C4 M T 01 → Standard version

Electrical and / or mechanical variants*:

- 01 Standard
- 08 Stainless steel 1.4404
- 11 Protection type IP69K (only with cable output)

Output:

- T 100Base-TX

Electrical connection:

- M Standard, 3 connectors radial
- Mx Connector output radial (x = number of outputs**)
- Tx Connector output axial (x = number of outputs**)
- Ky Cable output radial (y = cable length)
- Ly Cable output axial (y = cable length)

Profile:

- C4 Standard, PROFINET

Measuring range:

Singleturn: leave blank

1 ... 4096 Revolutions

Output code:

- R Binary code, position value format integer32
- W Binary code, position value format 2x integer16, resolution not adjustable
- S Binary code, position of the slew ring in integer32

Resolution:

- 4096 steps / 360° ↯
- 8192 steps / 360° ↯ (For output code S enter always 8192)

Housing material:

- A Aluminium housing
- S Stainless steel (1.4305) housing

Flange form:

- 58 K Clamped flange, shaft 10 mm with flat
- KF Clamped flange, shaft 10 mm with woodruff key
- KP Clamped flange, shaft 10 mm with parallel key (recommended for safety)
- KZ Clamped flange, shaft for play-compensating toothed gear ZRS
- S Synchro flange, shaft 6 mm
- SR Synchro flange, clamping shaft 12 mm (torque plate see accessories)
- ST Synchro flange, shaft 6 mm with flat
- 64 HP Heavy duty flange for shaft loads up to 500 N, shaft 10 mm with parallel key
- NZ Cam switch flange, shaft for play-compensating toothed gear ZRS
- 65 S Synchro flange, shaft 12 mm
- SP Synchro flange, shaft 12 mm with parallel key
- 66 K Clamped flange, shaft 10 mm with flat
- KP Clamped flange, shaft 10 mm with parallel key
- 90 MP Mounting flange, shaft 12 mm with parallel key
- 105 M Mounting flange, shaft 12 mm
- MP Mounting flange, shaft 12 mm with parallel key

Design form:

TRT T-Series multi turn with PROFINET interface

* The basic versions according to the data sheet bear the number 01. Deviations are identified with a variant number and are documented in the factory.

** Number of outputs:

- 1 = Hybrid
- 2 = 1x power supply, 1x PROFINET
- 3 = 1x power supply, 2x PROFINET

Absolute encoder model TRT

Accessories, documentation, GSD file

Accessories (to be ordered separately)

- Documentation on CD
 - TWK-CD-01** CD-ROM with documentation, device description file, bitmap and example programme
- Straight mating connector
 - STK4GP81** for PROFINET in/out
 - STK4GS60** for the supply voltage
 - STK4GP110** for PROFINET in/out (stainless steel 1.4404)
 - STK4GS104** for the supply voltage (stainless steel 1.4404)
- Angled mating connector (can only be used with aligned device connectors (option))
 - STK4WP82** for PROFINET in/out
 - STK4WS61** for the supply voltage
- Connecting cable
 - KABEL-xxx-114** Industrial Ethernet data cable with M12 connectors, D-coded, moulded on at both ends.
Standard lengths: 1, 2, 3 and 5 m (xxx = length in metres)
 - KABEL-xxx-118** Industrial Ethernet data cable with M12 connector to RJ 45, IP 20 (xxx = length in metres)
- Couplings
 - BKK** Folding bellows coupling, large, see data sheet [BKK11840](#)
 - BKM** Folding bellows coupling, small, see data sheet [BKM11995](#)
 - KK14S** Clamp coupling, see data sheet [KK12301](#)
- Toothed gear
 - ZRS** Play-compensating toothed gear [ZRS11877](#)
- Torque plate
 - ZMS** see data sheet [ZMS12939](#)
- Further installation accessories and securing clamps are available according to data sheet [MZ10111](#) .

Documentation, GSD file, etc.

The following documents plus the GSD file, a bitmap and example programmes can be found in the Internet under www.twk.de in the documentation area, model TRT.

- Data sheet TRT12886
- Manual No. [TRT12887](#)

Optionally, a CD-ROM can be supplied. (Please specify article No. TWK-CD-01 on ordering.)

Absolute encoder model TRT

Installation drawings

Standard design

Design form 58 with clamped flange, order number: TRT58-KA8192R4096C4MT01

Shaft \varnothing 10 mm

Dimensions in mm

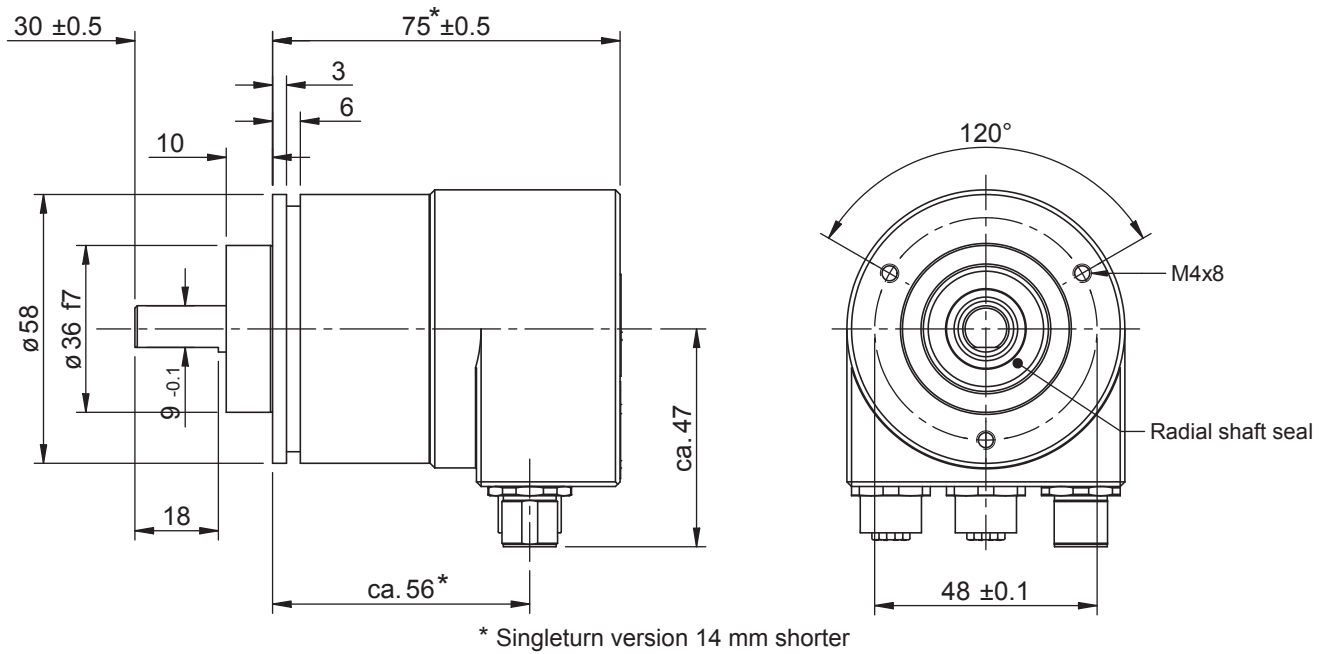

■ Optional: Shaft "P" with groove and parallel key

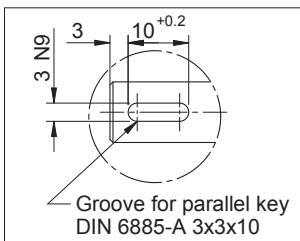

Rear view with connector M12

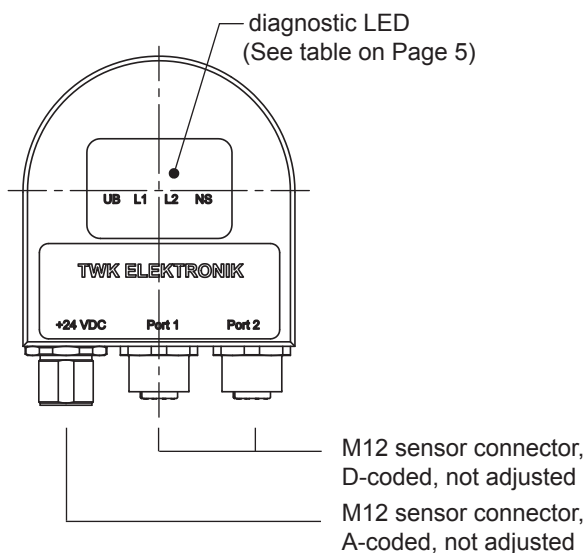

Rear view with cable output

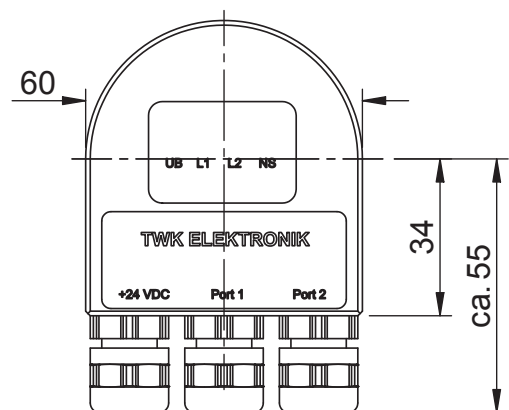

Absolute encoder model TRT

Installation drawings

Further possible designs

Design form 58 with **synchroniser flange**, order number: TRT58-SA8192R4096C4MT01

Shaft \varnothing 6 mm

Dimensions in mm

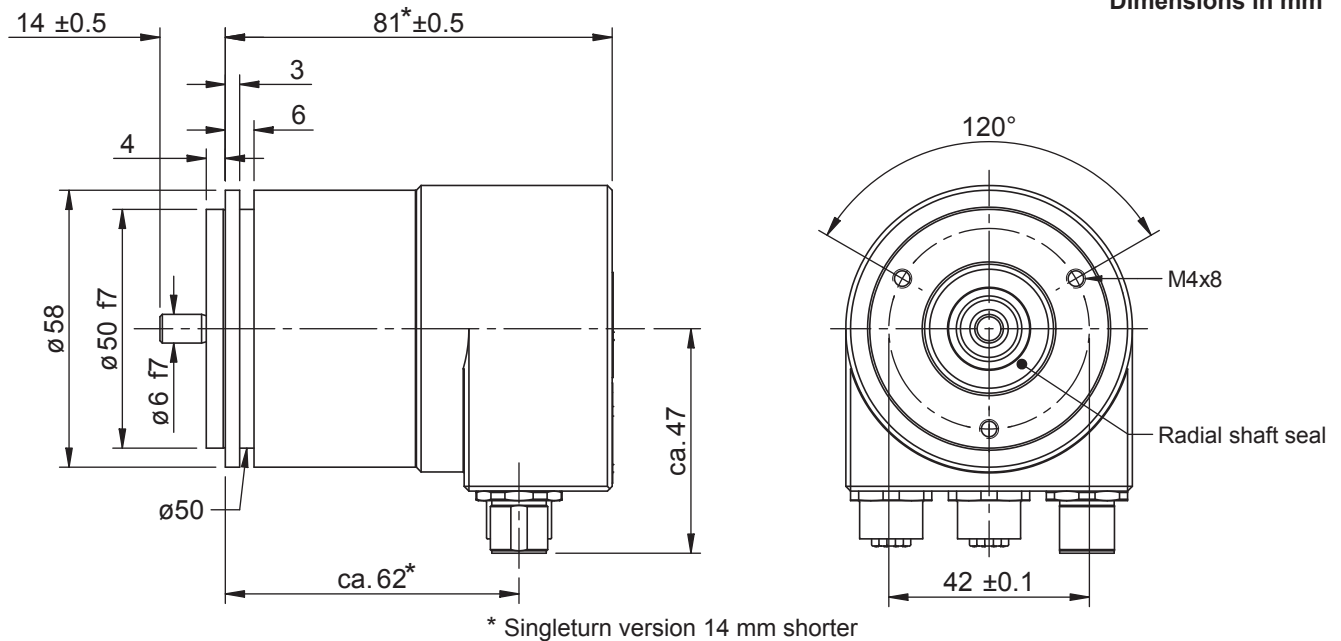

Design form 65 with **synchroniser flange**, order number: TRT65-SA8192R4096C4MT01

Shaft \varnothing 12 mm

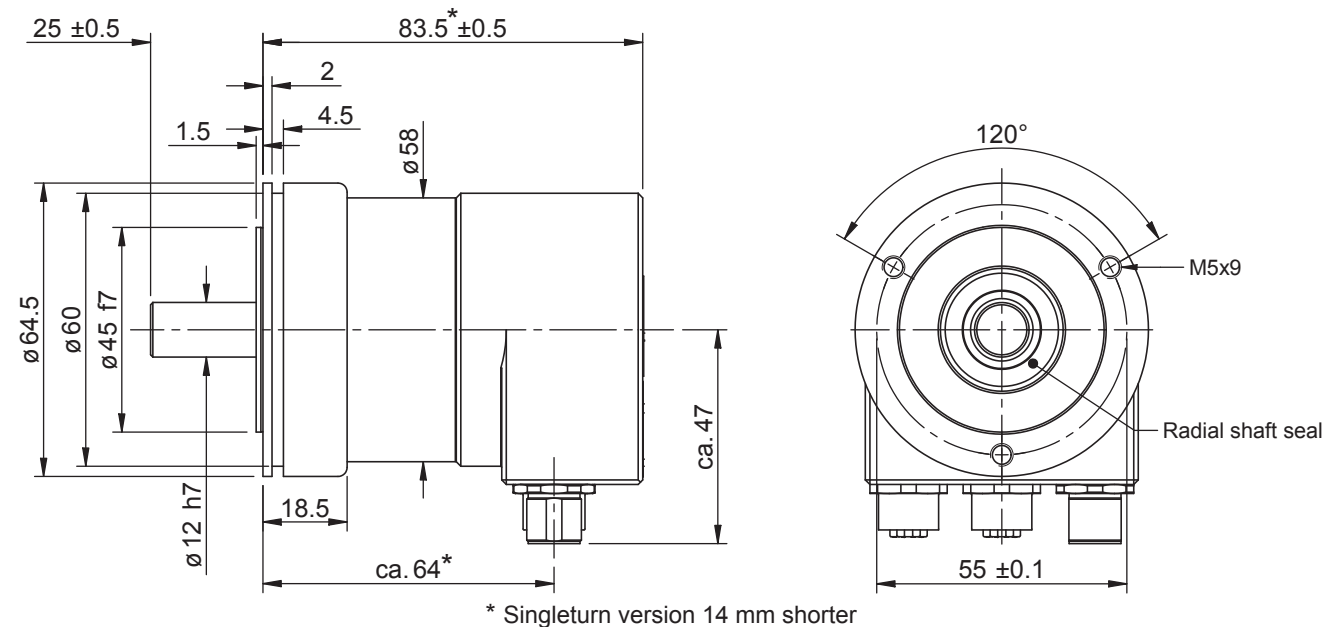

■ Optional: Shaft "P" with groove and parallel key

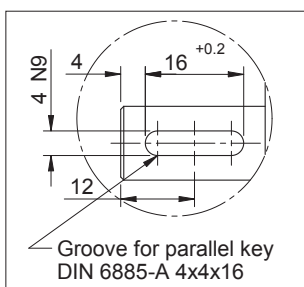

Absolute encoder model TRT

Installation drawings

Design form 64 with **switching cam encoder flange**, order number: TRT64-NZA8192R4096C4MT01

Shaft \varnothing 12 mm with flattened area, for mounting the toothed gear

Dimensions in mm

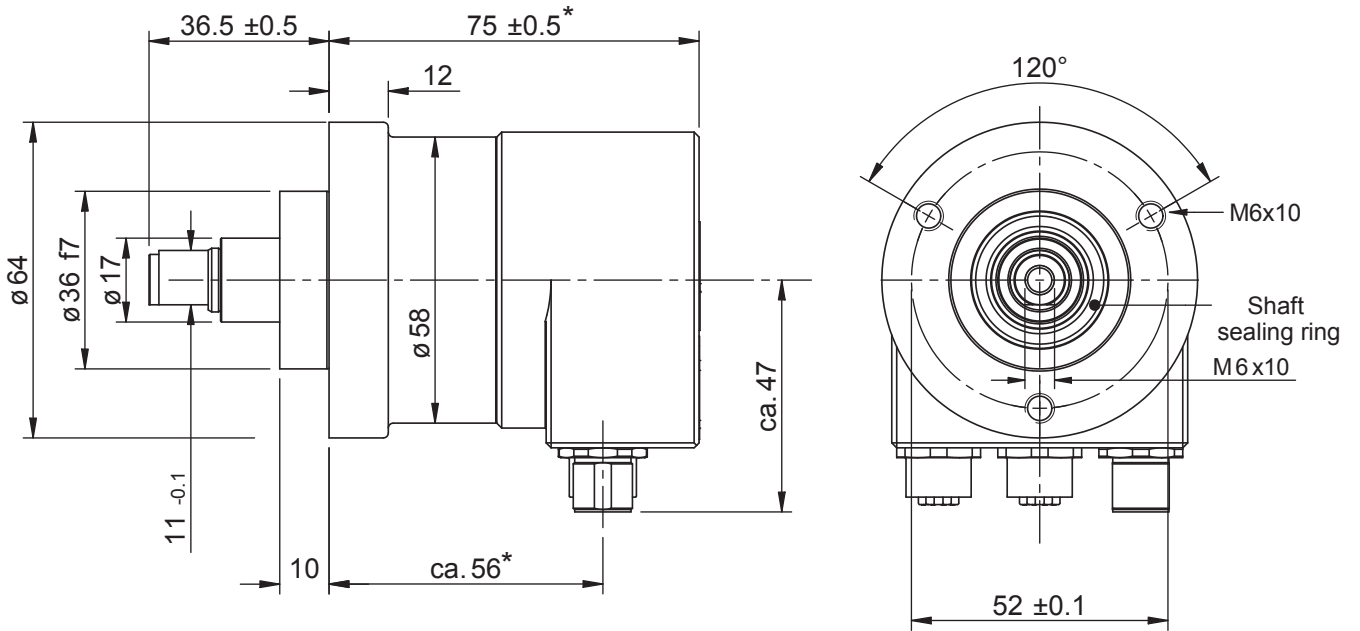

* Singleturn version 14 mm shorter

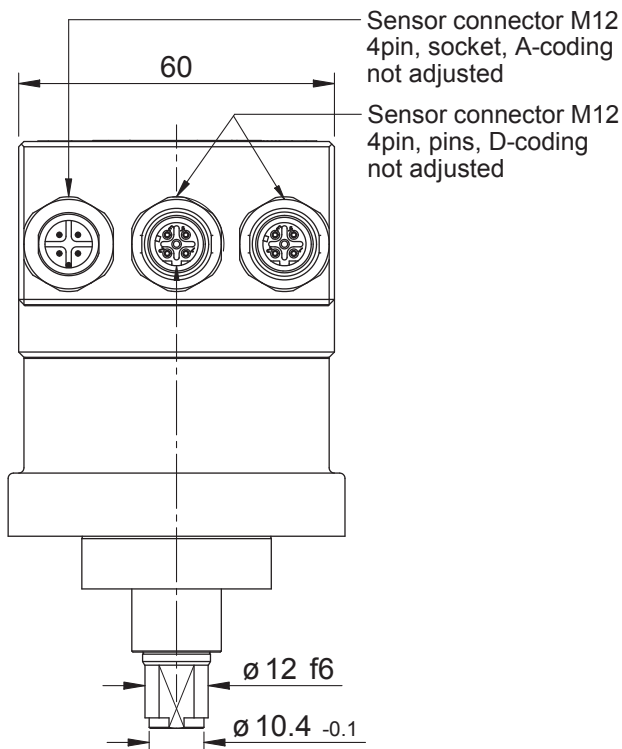

Absolute encoder model TRT

Installation drawings

Design form 58 with synchroniser flange and clamped shaft, order number: TRT58-SRA8192R4096C4MT01
 Shaft \varnothing 12 mm (other shaft diameters on request)

Dimensions in mm

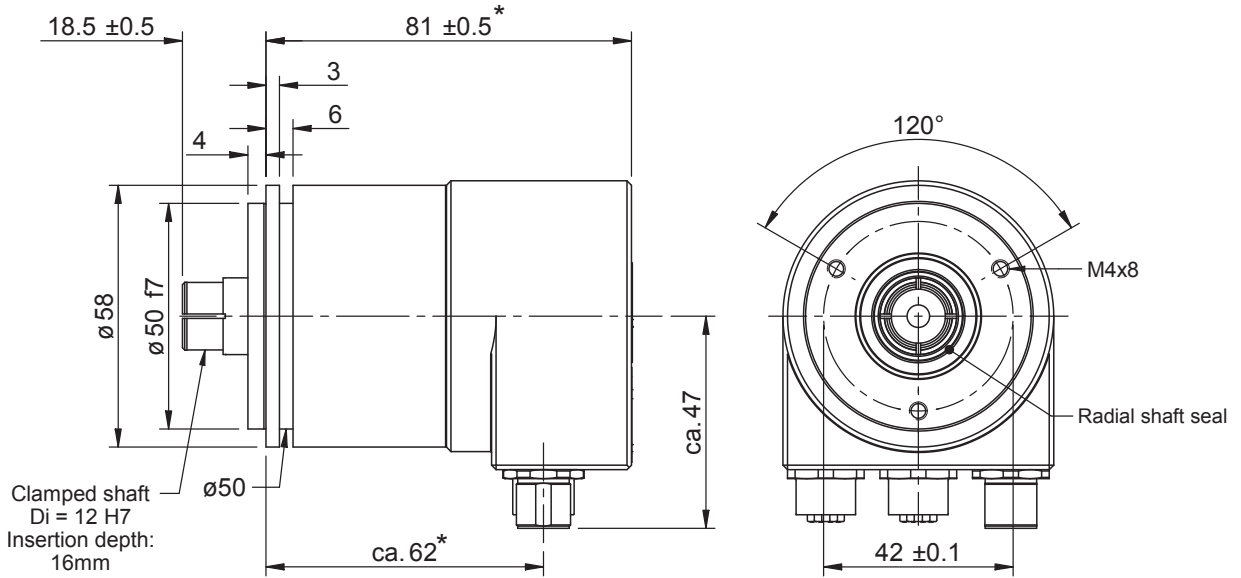

* Singleturn version 14 mm shorter

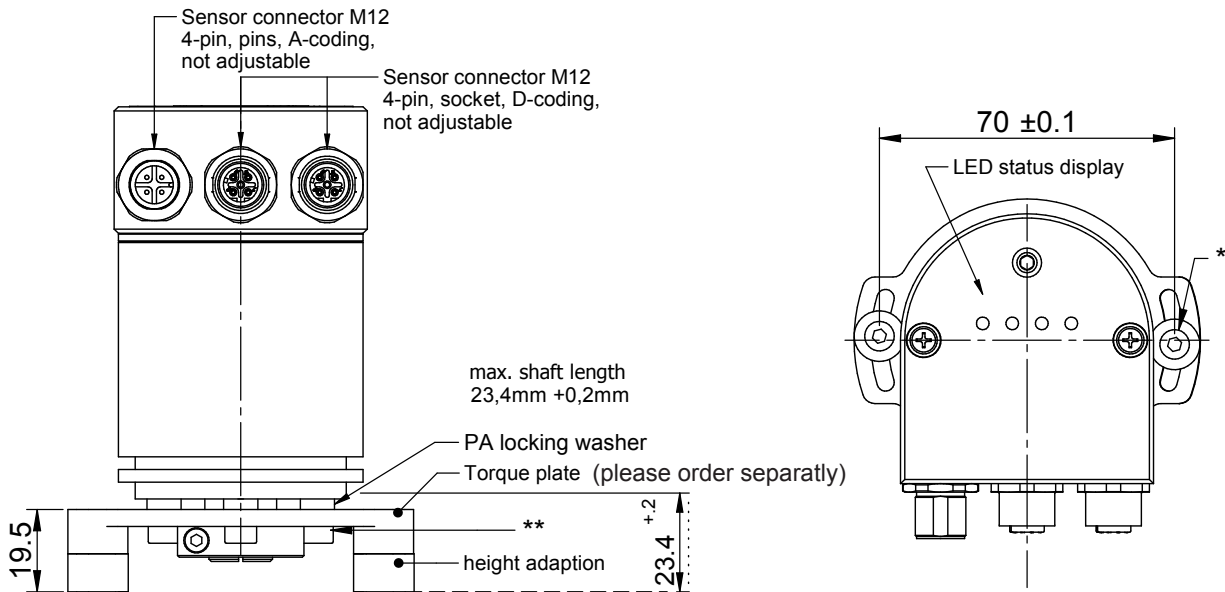

Reducing bush (please order separatly)

Ordering code: ZRH-A-12-X
 X = 6, 6,35, 8, 9,53, 10

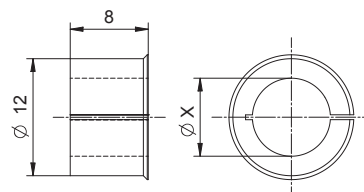
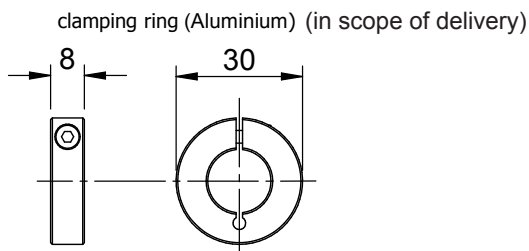

* 2x screw DIN 912 M4x30 (VA) with 2x locking washer (VA) and 2x flat washer DIN 9021-4,3.

** 3x screw DIN 912 M4x10 (VA) with 3x locking washer (VA).

Absolute encoder model TRT

Installation drawings

Design form 58 with 2 axial connectors, order number: TRT58-KA8192R4096C4T2T01

Shaft \varnothing 10 mm with flat

Dimensions in mm

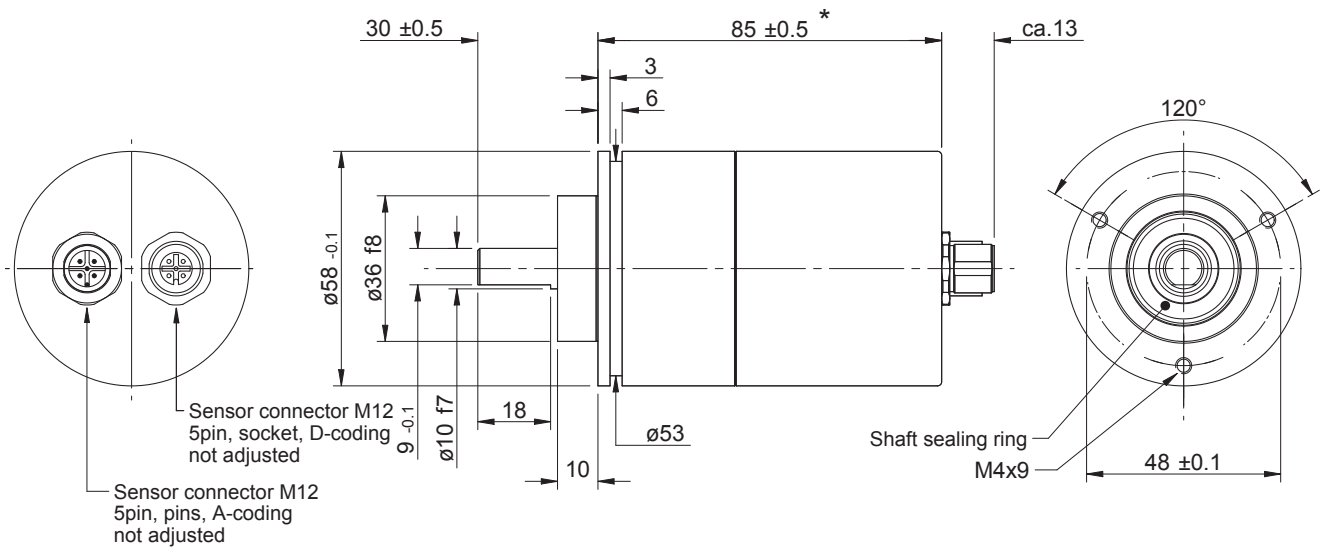

* Singleturn version 14 mm shorter

Design form 105, order number: TRT105-MA8192R4096C4MT01

Shaft **12** mm

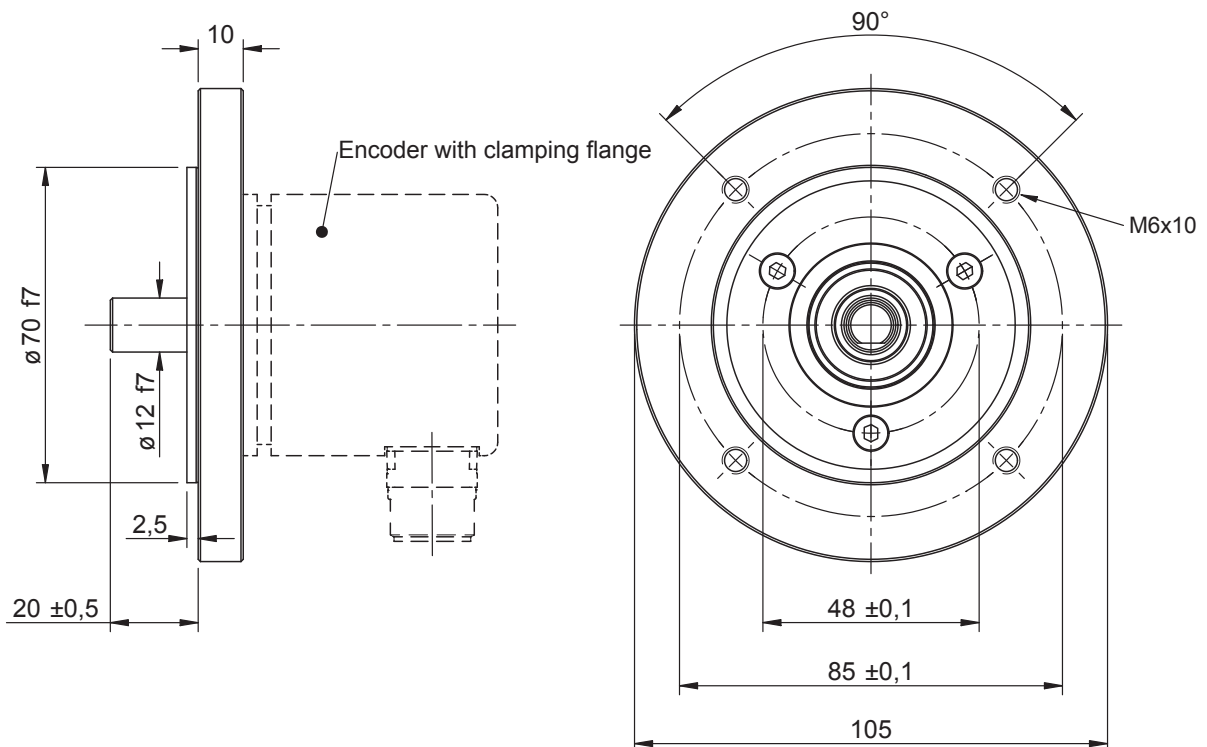

Absolute encoder model TRT

Installation drawings

Design form 64 with heavy duty flange, order number: TRT64-HPA8192R4096C4MT01

Shaft \varnothing 10 mm with flat

Dimensions in mm

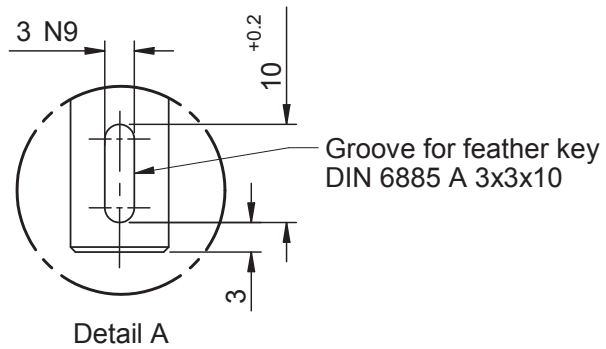
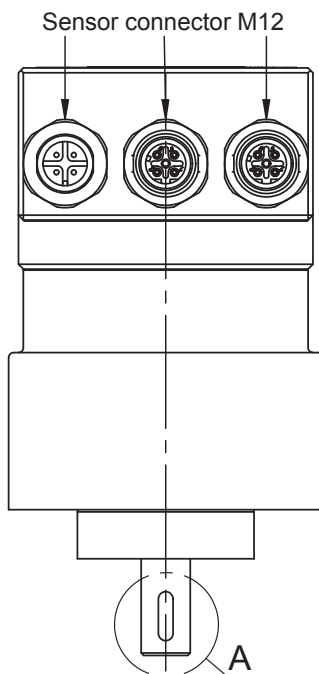
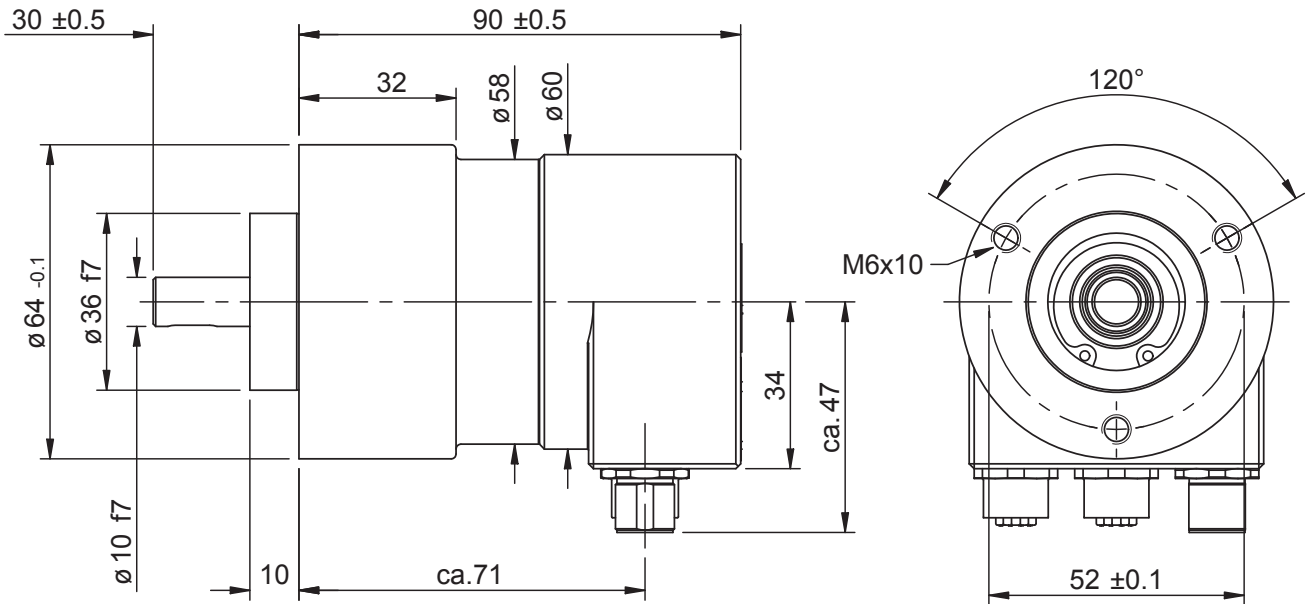

■ Suitable mounting bracket MW-S-03, see [MZ10111](#)